

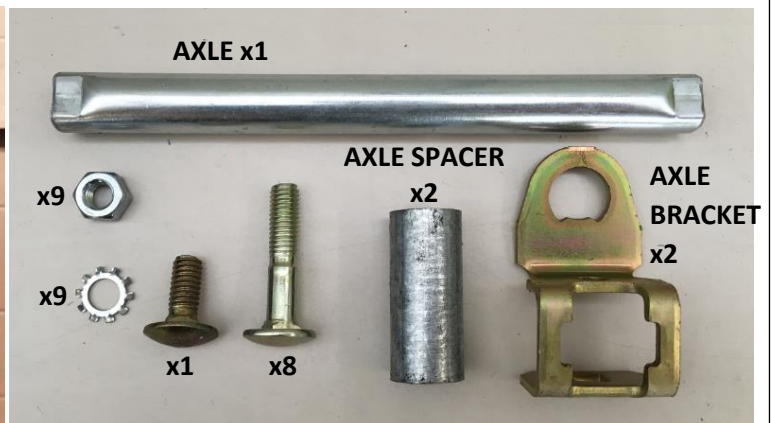

CAUTION! - INFLATE TYRE WITH CARE. DO NOT EXCEED RECOMMENDED PRESSURE. ENSURE SQUARE NECK OF BOLTS ARE LOCATED IN BOWL DURING ASSEMBLY.

TIP – PLACE STRONG TAPE OVER THE HEAD OF THE BOLTS TO HOLD THEM IN POSITION DURING ASSEMBLY. USE A MALLET TO KNOCK COMPONENTS INTO POSITION IF NEEDED.

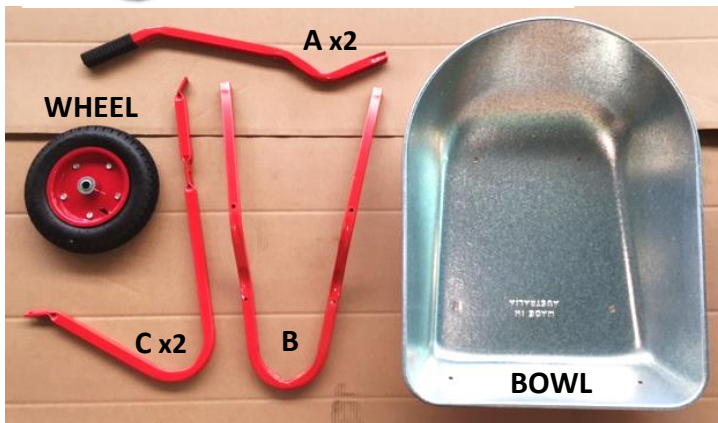

1. PLACE WHEELBARROW BOWL UPSIDE DOWN OVER A BENCH OR TABLE EDGE.
2. ASSEMBLE HANDLES "A" INTO FRONT FRAME "B" AS PER DIAGRAM. LOCATE ASSEMBLY OVER THE HOLES IN THE BOWL. INSERT 2 x LONG BOLTS FROM INSIDE THE BOWL AT POSITION 1 AND FINGER TIGHTEN WITH WASHERS & NUTS.
3. ASSEMBLE LEGS "C" TOGETHER IN A CROSS-PATTERN AT POSITION 2 WITH 1 x SHORT BOLT AND FINGER TIGHTEN WITH WASHER & NUT.
4. LOCATE THE LEGS OVER THE BOWL AS SHOWN AND FIX WITH 4 x LONG BOLTS AT POSITION 3 & 4. FINGER TIGHTEN WITH WASHERS & NUTS.

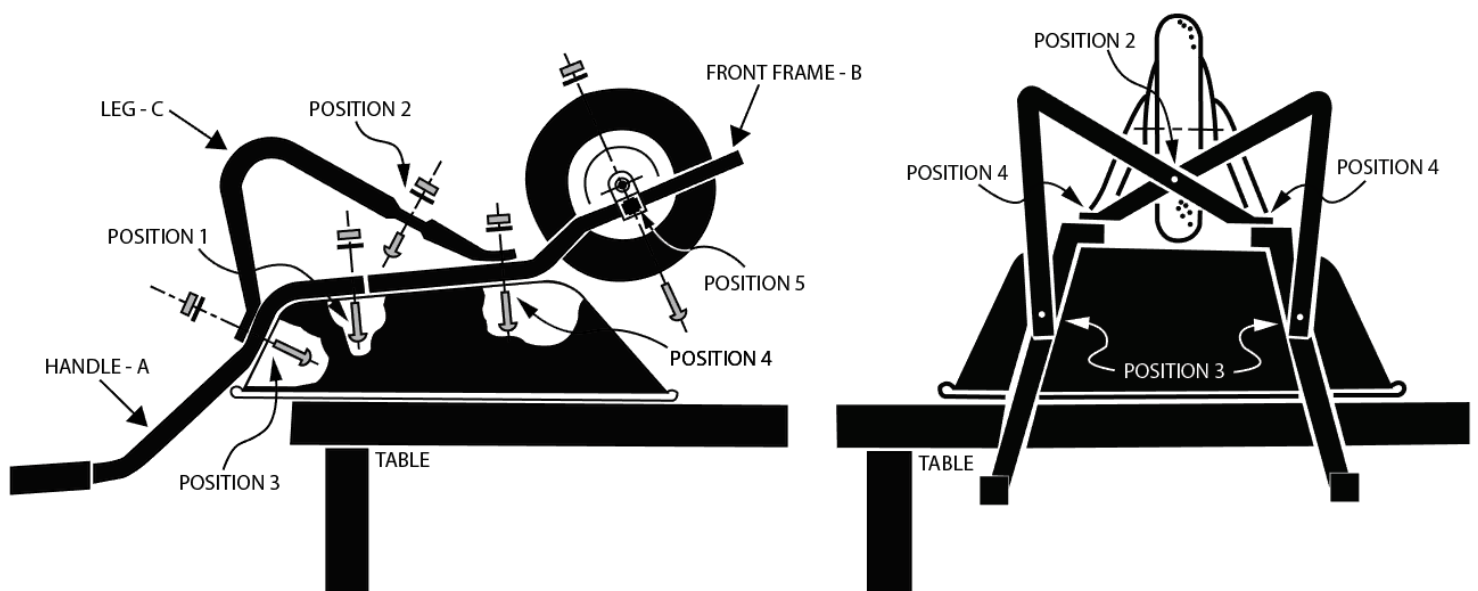

FITTING THE WHEEL

5. INSERT AXLE THROUGH THE WHEEL HUB.
6. SLIDE AXLE SPACER OVER EACH END OF AXLE. ENSURE AXLE AND SPACER ARE POSITIONED CENTRAL IN THE HUB.
7. LOCATE ONE AXLE BRACKET AT POSITION 5 ON FRONT FRAME "B". SECURE BRACKET WITH 1 x LONG BOLT AND TIGHTEN WITH WASHER & NUT AS SHOWN IN DIAGRAM BELOW.
8. INSERT ONE END OF AXLE AND WHEEL ASSEMBLY INTO THE AXLE BRACKET. ENSURE THE FLAT EDGE ALIGNS WITH THE FORM OF THE AXLE BRACKET.
9. SLIDE THE SECOND AXLE BRACKET INTO POSITION ON THE OTHER SIDE OF THE FRAME. ALIGN THE AXLE TO ENSURE IT SLOTS INTO POSITION AT THE SAME TIME.
10. SECURE AXLE BRACKET WITH 1 x LONG BOLT AND TIGHTEN WITH WASHER & NUT.
11. CHECK OVER ENTIRE ASSEMBLY, FULLY TIGHTEN ALL BOLTS AND ENSURE THAT THE WHEEL IS FREE TO SPIN.

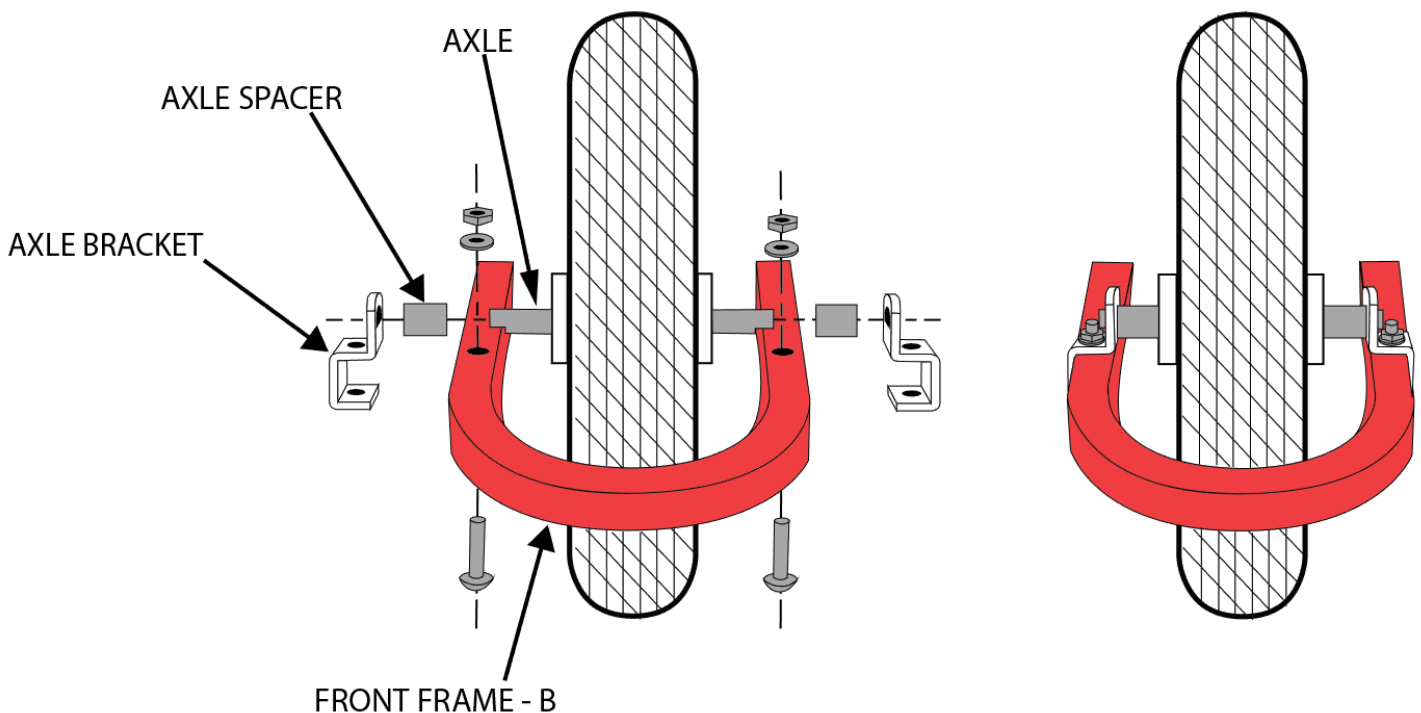

Manufactured/Supplied by Daytek Australia Pty. Ltd.

77-81 Gower Street, Preston, Victoria 3072 Australia

T +61 3 9470 1755 F +61 3 9470 5381

For more details on the Daytek range of products
please visit our website

daytek.com.au

